

Measurement Range:	0-100 % oxygen
Output in ambient air:	13 to 16mV
Electrical Interface:	3,5mm Mono Jack
Accuracy and Repeatability:	< 1 % vol. O ₂ when calibrated at 100 % Oxygen
	< 3 % relative
Linearity error:	< 12 sec. to 90 % of final value
Response time:	< 200 µV in 100 % nitrogen applied for 5 min
Zero Offset Voltage:	< 0.5 % vol. O ₂ response to:
	10 % CO ₂ balance N ₂
	80% N ₂ O balance N ₂
	7.5% Halothane balance N ₂
	7.5 % Isoflurane balance N ₂
	7.5 % Enflurane balance N ₂
	9% Sevoflurane balance N ₂
	20% Desflurane balance N ₂
Cross Interference:	- 0.03 % rel. per % RH at 25°C
Influence of Humidity:	proportional to change in oxygen partial pressure
Influence of Pressure:	< 1% relative after a fall from 1m
Influence of Mechanical Shock:	0 to 50°C
Operating Temperature:	built-in NTC compensation
Temperature Compensation:	between +25 °C and +40 °C: 3 % relative error
Effect of Temperature Compensation (steady state):	between 0 °C and +50 °C: 8 % relative error
Operating Humidity:	0-99% RH non-condensing
Long Term Output Drift:	< 1 % vol oxygen per month
	typically < - 15 % relative over lifetime
Storage Temperature:	-20 to +50 °C
Recommended Storage:	+5 to +15 °C
Recommended Load:	≥ 10 kOhms
Warm-Up Time:	< 30 minutes, after replacement of sensor
Nominal Sensor Lifetime:	≥ 1.000 000 % vol oxygen hours
Weight:	approximately 28 grams
Warranty Period:	15 months
Part No.:	01-00-0021

Use the advantages:

- Meet DIN EN 21647
- Designed and manufactured according to EN ISO 9001 : 2000 and EN ISO 13485 : 2003
- Accurate and reliable response
- Resistant to N₂O
- Excellent signal stability
- High product quality
- Short lead times
- Technical support



All specifications are applicable at standard conditions: 1013 hPa, 25°C dry ambient air

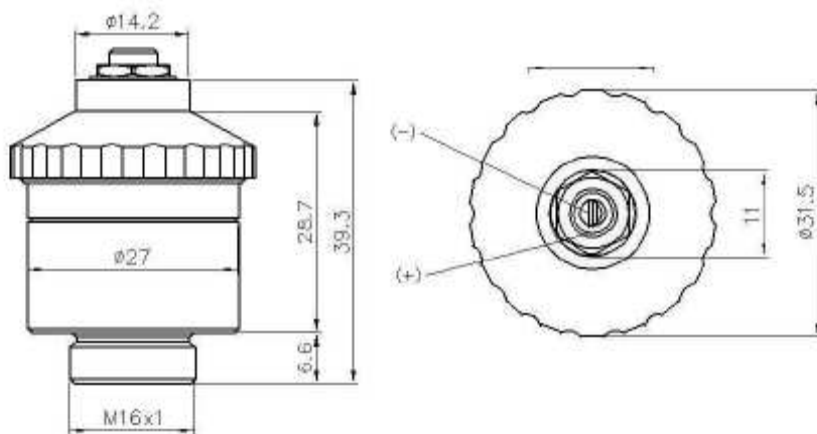

Dimension in mm

ENVITEC- WISMAR GMBH

Alter Holzhafen 18
D-23966 Wismar

Phone: +49-(0) 3841- 360 1
Fax: +49-(0) 3841- 360 222
E-Mail: info@envitec.com
<http://www.envitec.com>